

erties to vary much from those to be expected upon the basis of a constant value of "a."

One of the very valuable results of this study is the knowledge of the standard potentials in these media of varying dielectric constant since they may be used for the accurate determination of the ionization constants of weak electrolytes according to the method employed in this Laboratory.^{18,19} For purposes of convenience, the following equations for the standard potentials which summarize all these results are given below.

$$X = 0; E_0 = 0.22237 - 639.64 \times 10^{-6}(t - 25) - 3.181 \times 10^{-6}(t - 25)^2$$

$$X = 20; E_0' = 0.20303 - 760.5 \times 10^{-6}(t - 25) - 3.70 \times 10^{-6}(t - 25)^2$$

$$X = 45; E_0' = 0.16352 - 1135 \times 10^{-6}(t - 25) - 3.70 \times 10^{-6}(t - 25)^2$$

$$X = 70; E_0' = 0.06395 - 1767 \times 10^{-6}(t - 25) - 3.70 \times 10^{-6}(t - 25)^2$$

$$X = 82; E_0' = -0.0413 - 2370 \times 10^{-6}(t - 25) - 8.80 \times 10^{-6}(t - 25)^2$$

These have a range of validity from 0 to 50° inclusive. The uncertainties involved in these values have been discussed previously.

(18) Harned and Ehlers, *THIS JOURNAL*, **54**, 1350 (1932).

(19) Owen, *ibid.*, **56**, 24, 1695 (1934).

Summary

1. The thermodynamic properties of hydrochloric acid in dioxane-water mixtures covering a temperature from 0 to 50° and a dielectric constant range from 80 to 9 have been summarized and discussed. This is the most comprehensive study of such properties of a single electrolyte as a function of the electrolyte concentration, temperature and dielectric constant.

2. The results and calculations have been submitted to a critical survey. The ranges of acid concentration, temperature and dielectric constant within which accurate results may be obtained with the electrodes employed have been determined. Experimental errors have been estimated, and uncertainties in the extrapolations pointed out.

3. The results have been discussed in relation to the extended interionic attraction theory and Bjerrum's theory of ionic association.

4. Equations for the standard potentials of the cells $H_2 | HCl(m), \text{dioxane}(X), H_2O(Y) | AgCl-Ag$ in media containing 0, 20, 45, 70 and 80% dioxane are given.

NEW HAVEN, CONN.

RECEIVED SEPTEMBER 13, 1938

[CONTRIBUTION FROM THE GATES AND CRELLIN LABORATORIES OF CHEMISTRY, CALIFORNIA INSTITUTE OF TECHNOLOGY, No. 660]

A Comparative Method of Measuring Vapor Pressure Lowering with Application to Solutions of Phenol in Benzene

BY EDWIN N. LASSETTRE AND ROSCOE G. DICKINSON

Dilute solutions of many organic compounds in inert solvents have properties which may be explained on the basis of equilibria between the unpolymerized solute and polymers of all orders.¹ These solutions have been investigated either by studying the lowering of the freezing point, raising of the boiling point, or by studying the distribution of solute between water and the inert solvent. The first two of these methods do not permit a study to be made over an arbitrary temperature range; moreover, the determinations are not isothermal. The results from the third method are often difficult to interpret because of reaction of the solute with water which has been demonstrated in some cases to have an important influence on the equilibrium.²

(1) Lassettre, *THIS JOURNAL*, **59**, 1383 (1937); *Chem. Rev.*, **20**, 259 (1937).

(2) Szyzkowski, *Z. physik. Chem.*, **131**, 175 (1927); Cohen and Sabaro Miyake, *ibid.*, **119**, 247 (1926); Cohen and Van Dobbenburgh, *ibid.*, **118**, 37 (1925).

These objections are overcome by studying the distribution of a volatile solvent between two non-volatile solutes; one solute is the substance under investigation and the other, a comparison substance of known behavior. The procedure consists in preparing two solutions of the different solutes and connecting them through the vapor phase. Solvent then distils from the solution of high vapor pressure to the solution of low vapor pressure. The distillation is followed by measuring the volumes of the two solutions; the equilibrium volumes are determined by approach from both sides. This principle has been used by other investigators for special purposes³ but the methods employed were not well adapted to our needs.

Apparatus and Experimental Procedure.—The essential features of the apparatus are shown in Fig. 1. Solutions are introduced through the tubes H, a solution containing

(3) Barger, *J. Chem. Soc.*, **87**, 1042 (1905); Sinclair, *J. Phys. Chem.*, **37**, 495 (1933).

a known weight of comparison substance being placed in one side and one of the substances under examination in the other. The tubes H are then sealed off; the apparatus is placed in a horizontal position and is evacuated through the mercury trap F, which serves to prevent distillation of solvent into the grease of the stopcock G during the later approach to equilibrium. The mercury trap and stopcock has two advantages over a simple tube sealed off after evacuation: (1) inert gases must be removed thoroughly if the transfer is not to be unduly slow; the stopcock permits subsequent evacuations if the first is inadequate; (2) the mercury trap permits the evacuation to be made without boiling and danger of mixing the solutions.

When in operation the apparatus is immersed horizontally in a thermostat having a glass window, and is continuously rocked about a horizontal axis, D. The distillation of solvent from one solution to the other is followed by determination of the volumes of the solutions at various times. For this purpose the apparatus is brought into a vertical position and the solutions allowed to drain into their respective graduated and calibrated tubes A, which are read through the glass window. In order to approach equilibrium from the opposite direction, solvent can be distilled readily from one solution to the other by holding a piece of ice temporarily against the appropriate vapor chamber. The approach to equilibrium from the opposite direction can then be followed as before.

Sources of Error.—With adequate evacuation, the precision of the experiment is limited largely by the occurrence of small differences of temperature between the two solutions. Thus with the solutions used, a temperature difference of 0.002° corresponds to a mole fraction difference of about 0.0001. Sufficiency of elimination of temperature differences was examined by placing measured amounts of naphthalene in both sides of the apparatus; in the absence of disturbing effects equilibrium should be attained when the concentrations become equal. At 25° it was found that temperature differences could be eliminated satisfactorily by vigorous stirring of the thermostat and symmetrical placing of the apparatus; but at higher temperatures it was necessary to improve the temperature equality. This was accomplished by placing the apparatus of Fig. 1 in a glass jar with a closely fitting cover through which the evacuating tube protruded. The jar was filled with thermostat water and some mercury to provide stirring, and was placed in the thermostat and rocked. The buffering effect of the water within the jar greatly reduced effects attributable to temperature difference.

The volume measurements were accurate to about 0.01 cc.; the volume of either solution near equilibrium was around 15 cc.

The rates of distillation were not found to be a reliable indication of the distance from equilibrium; hence the equilibrium concentration was taken between values reached by approach from opposite sides.

Description of Materials. Benzene.—Thiophene-free benzene was distilled with a 25-cm. fractionating column. The middle and constant boiling fraction was used. The benzene was preserved in contact with sodium and was used immediately upon being removed from contact with the sodium.

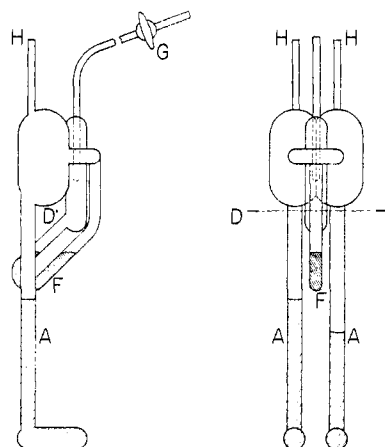

Fig. 1.—Two views of the apparatus in position for reading the solution volumes. During transfer of solvent the apparatus is rotated 90° about the fixed axis D so that the graduated tubes A are horizontal; it is rocked a few degrees about this position.

Phenol.—A good grade of phenol was distilled and the middle fraction used. The product obtained was entirely colorless. Analysis by bromination with potassium bromate-bromide solution showed at least 99.7% phenol. The analysis was intended to show that only a little water was present.

Naphthalene.—Eastman Kodak Co. naphthalene was used without further purification. The product melted sharply at 80.6° . Further purification did not change the melting point.

Azobenzene.—Kahlbaum azobenzene was used without further purification. The product melted sharply at 68.1° .

Sample Run with Azobenzene and Naphthalene.—Details of a run made with azobenzene solution in one arm and naphthalene solution in the other are given in Table I.

From the data of Table I it appears that the equilibrium volume of the azobenzene solution lies between 15.95 and 16.01 cc. while that of the naphthalene lies between 15.79 and 15.86. The observed ratio of volumes is accordingly 1.010 ± 0.003 . Freezing point experiments^{4,7} show that both azobenzene and naphthalene solutions in benzene follow the perfect solution laws so that the two solutions must reach equilibrium when the mole fractions are equal; at these low concentrations (0.1095 molar at equilibrium) this requires that the concentrations be equal to a sufficient degree of approximation and hence that the volumes be proportional to the moles of solute taken. The ratio of the moles taken is 1.010.

Results on Phenol.—Solutions of phenol in benzene were prepared by weighing phenol into a volumetric flask and diluting to the mark. Samples of this solution were transferred to the apparatus as needed. Solid naphthalene was weighed directly into the apparatus.

The results obtained are shown in Table II and graphically in Fig. 2. In the first column under Q are given

(4) Auwers, *Z. physik. Chem.*, **12**, 713 (1893).

TABLE I
SAMPLE RUN WITH AZOBENZENE AND NAPHTHALENE
0.3159 g. Azobenzene; 0.2199 g. Naphthalene; Temp. 25°

| Time, hours | Vol. azobenzene soln. | Vol. naphthalene soln. |
|--|-----------------------|------------------------|
| (a) After filling and evacuating | | |
| 0 | 15.46 | 16.39 |
| 11.5 | 15.76 | 16.05 |
| 24 | 15.83 | 15.98 |
| (b) After transferring solvent to azobenzene side | | |
| 0 | 16.56 | 15.25 |
| 4 | 16.23 | 15.56 |
| 23 | 16.11 | 15.71 |
| (c) After transferring solvent to naphthalene side | | |
| 0 | 15.66 | 16.15 |
| 12.5 | 15.93 | 15.88 |
| 22 | 15.95 | 15.86 |
| (d) After transferring solvent to azobenzene side | | |
| 0 | 16.14 | 15.68 |
| 1 | 16.08 | 15.73 |
| 2 | 16.06 | 15.75 |
| (e) After transferring solvent to naphthalene side | | |
| 0 | 16.04 | 15.77 |
| 14.5 | 16.01 | 15.79 |
| 24 | 16.01 | 15.79 |

the values for the number of formula weights of phenol per liter of solution at equilibrium. The second column under N gives the number of formula weights of naphthalene per liter of solution at equilibrium. A correction has been introduced for the thermal expansion of the solutions, all concentrations being corrected to 25°. The coefficients

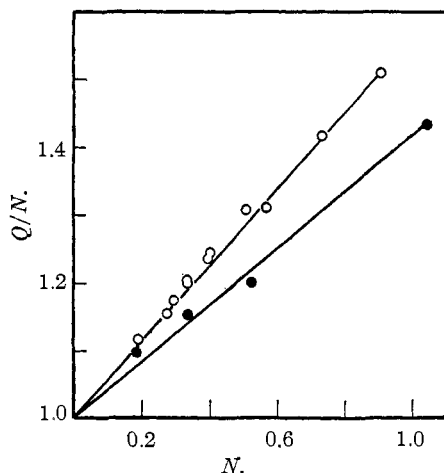

Fig. 2.—Polymerization of phenol in benzene solution: open circles, 25°; solid circles, 50°.

of expansion of the solutions are not known, but were computed from the known coefficients of expansion of pure benzene and pure phenol,⁵ on the assumption that the density of the mixture is a linear function of the composi-

(5) "International Critical Tables," 1928, Vol. III, p. 29.

tion. The densities of mixtures of phenol and benzene have been investigated at 20° and at this temperature the density is a linear function of the composition in weight per cent. The uncertainties given are the differences between the values obtained when the equilibrium was approached from both sides. The time consumed in a determination varied between eight and forty-eight hours, depending on the concentration and temperature.

The loss of phenol upon evacuation was examined by condensing the vapor in an experiment and analyzing for phenol. It was found at 25° that if 1% of the solution is pumped off, 0.02% of phenol is lost. The data in Table II are corrected for this loss.

TABLE II
PHENOL AND NAPHTHALENE SOLUTIONS OF EQUAL BENZENE VAPOR PRESSURES

| Phenol f. wts./liter Q | Naphthalene f. wts./liter N | Q/N |
|--------------------------|-------------------------------|---------------|
| 25.00 = 0.01° | | |
| 0.2221 | 0.1989 | 1.117 = 0.004 |
| .3162 | .2738 | 1.155 = .004 |
| .3480 | .2948 | 1.180 = .002 |
| .4014 | .3344 | 1.199 = .001 |
| .4010 | .3325 | 1.205 = .009 |
| .4884 | .3946 | 1.237 = .006 |
| .5023 | .4034 | 1.245 = .004 |
| .6634 | .5070 | 1.307 = .003 |
| .7369 | .5608 | 1.313 = .003 |
| 1.036 | .7314 | 1.416 = .004 |
| 1.368 | .9061 | 1.509 = .004 |
| 50.00 = 0.03° | | |
| 0.2018 | 0.1842 | 1.096 = 0.008 |
| .3909 | .3391 | 1.152 = .009 |
| .6386 | .5275 | 1.210 = .008 |
| 1.521 | 1.061 | 1.433 = .007 |

The distillation of phenol from one flask to the other was also examined under the most unfavorable conditions used, *i. e.*, at 50° with a phenol concentration of 1.5 molar. After a run of fifteen hours the naphthalene solution was analyzed for phenol, and it was found that it contained 0.25% of the original phenol. This corresponds to an error of 0.5% in the experiment since distillation of phenol reduces the phenol concentration and effectively increases the naphthalene concentration. For this reason the time of the determinations was reduced as much as possible, and as a result equilibrium was not approached as closely as would be possible with entirely non-volatile solutes. No correction for this distillation is introduced.

Interpretation of Results.—If both the naphthalene and phenol solutions were perfect solutions the values of Q and N would be equal. It is known⁷ that solutions of naphthalene in benzene obey the perfect solution laws. The solutions of phenol in benzene have a higher formal concentration than the naphthalene solutions in equilib-

(6) Bramley, *J. Chem. Soc.*, **109**, 16 (1916).

(7) Beckman, *Z. physik. Chem.*, **2**, 715 (1888); Washburn, *Proc. Natl. Acad. Sci.*, **1**, 191 (1915).

rium with them. On the assumption that the two solutions reach equilibrium when their molar concentrations are equal, the abnormalities of the phenol solutions become attributable to polymerization of the phenol; with this interpretation N gives the number of moles of phenol per liter of solution, each polymer being counted as a single molecule.

There is, of course, a certain arbitrariness in attributing the failure of Raoult's law to any one cause to the exclusion of others.⁸ However, of other possible causes, association of the solvent is, in the present case, very improbable. Again, the effect of any solvation of the phenol on the benzene vapor pressure would be in a direction opposite to that observed; solvation may, of course, occur in addition to polymerization. It is further to be noticed that the observed deviations from Raoult's law are considerable in fairly dilute solution.

The data of Fig. 2 show that Q/N is a linear function of N within the limits of experimental error. The slope is 0.570 at 25° and 0.416 at 50°.

When Q/N is greater than unity and is a linear function of N , it has been demonstrated previously² that an interpretation in terms of the law of mass action leads to the conclusion that polymers of all orders are present and that the equilibrium constant of the polymerization reaction



is given by the formula

$$K_l = \beta^{l-1} \quad (2)$$

where β is the slope of the line and may also be interpreted as the equilibrium constant of the dimer, *i. e.*, K_2 . Thus the values of K_2 are 0.570 and 0.416 at 25 and 50°, respectively.

The distribution of phenol between water and benzene has been studied recently by Philbrick.⁹ The equilibrium constant K_2 determined under these conditions at 25° is 0.575. This agrees very well with that obtained in the present study, *i. e.*, 0.570.

(8) This is emphasized by Hildebrand, "Solubility," Reinhold Publishing Corp., New York, N. Y., 1936, p. 119.

(9) Philbrick, *THIS JOURNAL*, **56**, 2581 (1934).

The change in heat content upon formation of the dimer, $(\text{C}_6\text{H}_5\text{OH})_2$, can be calculated from the values of K_2 at 25 and 50°. We obtain in this way 2400 ± 300 cal./mole for the change in heat content. The uncertainty given is an estimate based on the uncertainty in the slope at 50°.

It is now usually assumed that the polymerization of phenol arises from hydrogen bond formation; if this be the case it seems very unlikely that the dimer of phenol can have more than one hydrogen bond. If the dimer has only one hydrogen bond, we would expect that the heat of dissociation would approximate the hydrogen bond energy. As a matter of fact 2400 cal./mole is much less than the usual estimates of hydrogen bond energy.¹⁰ This might be interpreted as due to interaction with solvent, or merely to a very weak hydrogen bond. These equilibria have been studied so little, however, that speculation does not seem justified. From relation 2 and the values of β at 25 and 50° the heat of reaction for any polymerization reaction can be calculated. It will be evident, however, that due to the uncertainties in the experimental data it is unsafe to extend this calculation beyond the trimer at most, and even in this case the uncertainty is large.

Summary

1. A comparative method of determining vapor pressure lowering is described which makes use essentially of the distribution of a volatile solvent between two non-volatile solutes. The accuracy of the method in its present form is better than 1% in solutions as dilute as 0.1 *m*, and the method is comparatively flexible.

2. The concentrations of solutions of phenol in benzene and solutions of naphthalene in benzene having the same benzene vapor pressure have been determined at 25 and 50°, and have been discussed in terms of polymerization.

3. An approximate value of 2400 cal./mole for the heat of dissociation of the dimer of phenol is obtained.

PASADENA, CALIFORNIA

RECEIVED AUGUST 29, 1938

(10) Huggins, *J. Org. Chem.*, **1**, 407 (1936).